

DfE Census 2012 for Devon LA Personalized Learning Services (Pupil Referral Units)

Census Date: 19 January 2012

Return Date: 27 January 2012

Guidance Notes for Pupil Referral Units

These guidance notes combine the guidance produced by the Department for Education (DfE) relating to data requirements with instructions on producing the information via SIMS.net.

This guidance is broken down into several sections.

- **Introduction by the DfE** which explains the background to the return
- **Running the census** which explains how to run, check and submit the census
- **Annexe 1 – Establishment Details** gives the information required at establishment level, with information on acceptable values and how to input.
- **Annexe 2 – Pupil Details** gives the information required at pupil level, with information on acceptable values and how to input.

IMPORTANT NOTE:

It is **vital** that you have completed the Autumn upgrade to 7.142 in order to run the January School Census.

Changes from 2011

- Funded hours are being collected as well as Hours at Setting. *(These data items only relate to pupils aged under 5 on 31 August 2011)*
- The Service Children indicator *is* being collected this year
- The Gifted and Talented indicator is no longer being collected
- Mode of Travel is no longer being collected
- In Care information will only be collected for excluded pupils
- Source of Ethnicity is no longer being collected
- There are changes to the Individual Pupil Persistent Absentee Threshold – see page 34.
- The **Calculate All Details** button is now in the first section: **Census Details**

Help

If you need additional assistance in completing your return, help is available as follows:

- **On line** help is available by clicking the 'Help' button in the top right hand corner within the Census
- **Contact** the ScoMIS Helpdesk 01392 385300 for all technical queries.
- **Contact** Jane Batten on 01392 383281 for all data queries
- Or, you may **email** a data query to census@devon.gov.uk
- A **flowchart** to help you through the process is given in Annexe 3

- Additional guidance on including/excluding pupils on roll is contained in 'DfE Detailed Guidance for School Census' available from the following website www.devon.gov.uk/schoolcensus

Index

Help	1
Introduction by the DfE	4
Changes from 2011	4
Preparation	5
Before you begin	6
Running the School Census	6
<u>1</u> Census Details	8
<u>2</u> School Information	9
<u>3</u> Hours at setting	10
<u>4</u> Time in Unit	10
<u>5</u> Provider Status	11
<u>6</u> Teachers	11
<i>Who to include</i>	11
<i>Where to include them</i>	12
<u>7</u> Support Staff	14
<i>Who to include</i>	14
<i>Where to include them</i>	15
<u>8</u> Pupil Attendance	16
<u>9</u> Teenage Mothers	17
Create and Validate	18
Authorisation and Copying	19
Returning the file	20
Annexe 1 – School Information	21
School Name	21
LA Number	21
Establishment Number	21
School Phase	21
School Governance	21
Intake type	21
Highest NCY	21
Lowest NCY	21
School address	21
School Telephone Number	21
E-mail address	21
Annexe 2 – Pupil Information	22
Who to include	22
Legal Forename	23
Middle Names	23
Legal Surname	23
Preferred Surname	23
Former Surname	23
Date of Birth	23
Gender	23
Enrolment Status	23
Admission Date	24
Former UPNs (<i>Unique Pupil Numbers</i>)	24
UPNs (<i>Unique Pupil Numbers</i>)	24
ULNs (<i>Unique Learner Numbers</i>)	24
Part-Time Indicator	24
Year Taught in	24
Boarder Status	25

Home Information	25
Free School Meals Eligibility	25
Ethnicity	26
First Language	26
Connexions Assent	
In Care details	29
Date of Leaving	30
Special Educational Needs	31
Exclusions	33
Attendance	34
Annexe 3 - Flowchart	35

Introduction by the Department for Education (DfE)

The following factors are the business drivers behind the Pupil Referral Units Census

- It is consistent with the overall vision to:
 - Collect data once and use many times
 - Automate the collection of data
 - Data collected should be that which a well prepared PRU uses themselves or be justified with a clear business case
- It assumes that much of the data is already held in schools' MIS ready for transfer on Census day, so the need for data entry on the day is kept to a minimum.
- Given that the majority of the data collected at pupil level are those which a well managed PRU uses themselves, the data should be kept up to date on an event driven basis (ie data should be updated by the PRU as soon as it is aware of any change or addition so the update is event driven) and so the burden of collection by the Department should not be high.
- the majority of data collected are as defined in the Common Basic Data Set (CBDS) <http://www.education.gov.uk/schools/adminandfinance/schooladmin/ims/datamanagement/a0058744/common-basic-data-set-cbds-database>

Analysis of individual pupil records supports the drive to raise standards, provides accurate targeting of funding, and assists the monitoring and development of policy. For example, information about the numbers of pupils, teachers and education support staff is used to monitor pupil:adult ratios; information about pupils with statements, pupils with SEN but without statements (*School Action or Early Years Action and School Action Plus or Early Years Action Plus*), free school meals, ethnicity, absences and permanent exclusions is used to monitor the Government's social inclusion policy. Pupil numbers are used for funding LAs and schools (including development of the new Pupil Premium) and contributing to the School and College Performance Tables exercise. The collection and publication of attainment data on pupils in PRUs is vital to accountability for PRUs. Collecting pupil numbers and details is an important part of providing that accountability.

Data will also continue to be used nationally for the Standard and Testing Agency (STA) Key Stage 2 National Pupil Test Registration process. The data are used to support other key areas involving LAs such as Revenue Support Grant and LA Benchmarking Tables. Without this information it would be very difficult for Ministers, Parliament, central and local government, pressure groups and the public to monitor government policies and their effectiveness.

The submission of the Pupil Referral Census, including a set of named pupil records, is a statutory requirement on schools under section 537A of the Education Act 1996

<http://www.legislation.gov.uk/ukpga/1996/56/section/537A> The PRU Census being on a statutory basis ensures that:

- PRUs do not need to obtain consent to the provision of information from parents of individual pupils;
- PRUs and LAs are protected from any legal challenge that they are breaching a duty of confidence; and
- helps to ensure that returns are completed by PRUs.

Preparation

It is expected that the majority of your data will be up to date and if it isn't, running the Census as soon as possible and checking any validation errors and examining the Summary and Detail reports **thoroughly** will bring any errors/omissions to your attention. This will give you time to amend the data (most of which is date specific) **before** the census date.

You are advised to check the following:

- All new pupils are on the system
- Any leavers have been properly removed from the system
- Enrolment status is correct
- Eligibility to Free School Meals is up to date
- Special Education Needs pupils are properly recorded (remember that pupils on School Action Plus or who have a Statement will need a 'needs type')
- Part-Time pupils must be recorded as such (See **Annexe 2** page 38 for instructions on how to do this)
- Hours at Setting and Funded Hours for **all** pupils aged two, three or four on 31/08/2011 have been entered (See **Hours for two, three and four year olds**, page 8)
- Ensure that your attendance and exclusions data for the previous academic year is accurate

Before you begin:

Check you have the correct permissions to run the Census (**System Manager | Assign Users to User Group**) within System Manager. You will need to be assigned to either the Returns Manager or Returns Operator group. In order to resolve any Census failures/queries you may also need access to other areas of SIMS.net e.g. pupil details, school details etc. To do this you will also need to be a member of one of the following groups: Administration Assistant; Admissions Officer; School Administrator. The return should be authorised electronically by the Teacher-in-charge so they will also need the correct permissions.

Running the Census

Go to **Routines | Statutory Returns | PRU Census**

Please check the School Census Folder path is completed and correct. For networked schools the drive will be **G:** or **F:\Public**, standalone schools will use drive **C:** Then for all schools the path will be **SIMS\Star\ASCout** It is advisable to use the browser to set the file path rather than type it in.

Census Details

There is a facility that adds a security message which will appear at the top of each of your 'Detail Reports'. You may edit the default security message if you wish eg "Not to be removed from school property". This is done by typing in the text box.

Click **New** to create your return.

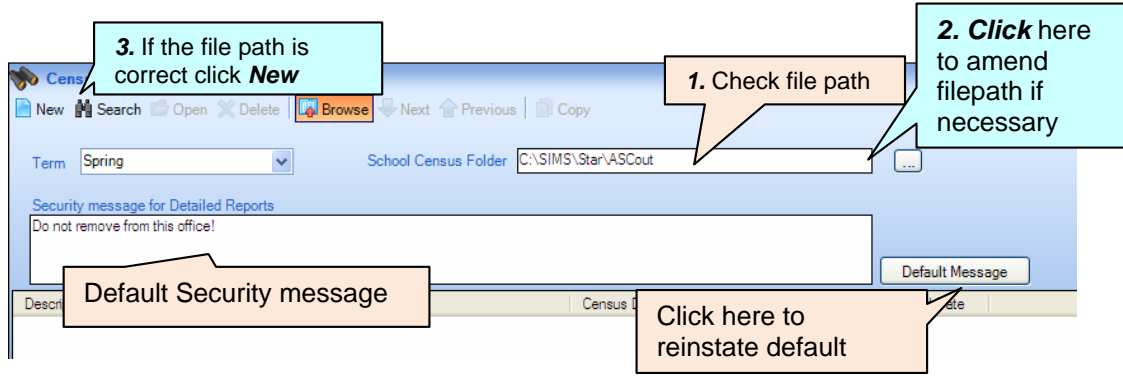

You will see the following screen:

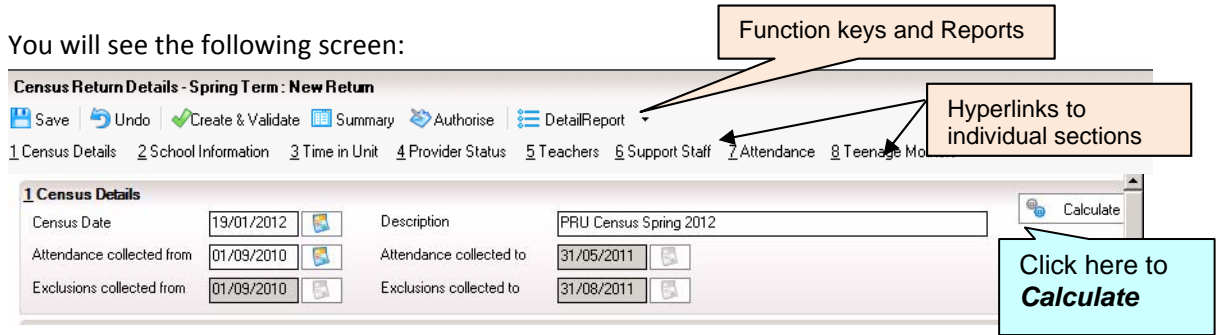

The correct **Census Date** will be entered automatically, as will the dates for the collection of the historical Attendance and Exclusions data.

*There is a default for the **Description** field e.g. PRU Census Spring 2012. If you create more than one **New** return (although this should not be necessary) you will need to amend the description. It is not necessary to amend the description if you're copying an existing authorised return (unless you want to) the system will rename it Copy of*

IMPORTANT NOTE: In order to open an **existing** return you will need to click 'Search' on the browser in order to see it first. Highlight it and then **Open**.

To collect the data from SIMS.net for your School Census return, click **Calculate All Details**, you will see the following message, click **Yes** to continue:

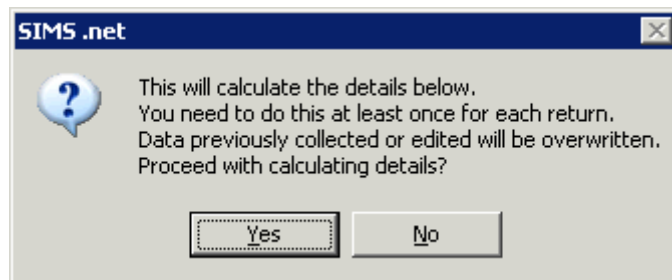

IMPORTANT NOTE: If nothing appears to happen when you click **Calculate All Details** please check the bottom left hand corner of the Census return for an error message as there may be an error in School Detail. See Annexe 1 for information on data requirements in School Details.

Save once you have **Calculated**.

IMPORTANT NOTE: You must complete the **Calculate All Details** once only for each **New** return. However, if you are returning to an **existing return**, i.e. you are selecting it from the list available it is vital you **don't** **Calculate All Details** again as you will overwrite any manual adjustments you may have made.

School Information

2 School Information

School Name: Red Abbey PRU

LA: 878 Establishment Number: 9999

School Address: Great Moor House
Bittam Road Exeter
EX2 7NL

Telephone: 01392 385300

School E-mail Address: admin@redabbey.devon

School Phase: PR Pupil Referral Unit (PRU)

School Type: Maintained Special (day)

Governance: Community Intake Type: Comprehensive

Pupil Genders: Coeducational Gender On Entry to School: Coeducational

Gender on entry to 6th form: Coeducational

Lowest NC Year: R Highest NC Year: 11

Number of Child Care Places: 0 Number of Child Care Nursery Places: 0

School Detail

Intake type should be Comprehensive

To enter this data, click on the **School Detail** button, add or edit the data by clicking the tick boxes, save it then click on the **OK** button to return to this screen. It is unlikely that any other information will need to be amended in the **School Information** section but follow the same procedure to make other amendments.

***School Phase:** This should be Pupil Referral Unit but may be set as Special or Secondary. If it is you cannot amend it. However it can be amended centrally once you have sent in your return. Fortunately, even if the phase is wrong, this should not affect the census return type as this is now based on your establishment number.

Please work through each of the following sections making amendments and editing data where necessary.

To edit a field click into it (except for hours at setting where it is necessary to click twice), if the field is empty (zero) type the correct figure in, if there is a value, highlight it and overwrite, then press enter or click elsewhere. You can either use the scroll bars to the right of the screen to get to each section, or the hyperlinks at the top of the screen e.g. **5 Teachers** to jump direct to that section.

Hours at Setting and Funded Hours *(It is only necessary to complete this section if you have pupils aged under 5 as at 31 August 2011)*

Update Hours for Nursery Children Recalculate

Age at date 31/08/2011

Pupil			Pupil			Pupil		
Name	Hours at Setting	Funded Hours	Name	Hours at Setting	Funded Hours	Name	Hours at Setting	Funded Hours
Clover, Frederick	12		Astwick, William	12		Adams, Laura	25	
			Candy, Tilly	12		Amnar, Tarak	25	
			Ching, Susie	12		Astwick, Gwenneth	25	
			Jackson, Carl	12		Bond, Steve	25	
			Jennings, Adam	12		Cameron, Zara	25	

Update Hours for 2 year olds Update Hours for 3 year olds Update Hours for 4 year olds

The DfE is collecting Funded Hours in addition to Hours at Setting. For the majority of establishments this will have little effect as Full-time pupils of normal school admission age will continue to be recorded as 25 hours for both Hours at Setting and Funded Hours.

Note: Hours at Setting should include all the hours a pupil is expected to attend during the week. (Full-Time pupils in Reception are deemed to attend 25 Hours). Funded Hours are the hours fundable under Direct Support Grant. (Full-Time pupils in Reception who are of Reception Age will be funded for 25 Hours).

However if you have part-time pupils in Reception there may be some variation between Hours at Setting and Funded Hours.

Hours at Setting

This is the total number of hours spent in **education provision** at the school irrespective of who funded the hours (ie it is the total of any hours funded under the free entitlement to nursery education plus any additional hours of education funded from other sources such as parents).

For dually registered pupils only the actual hours attending each school should be recorded. The main registration should **only** include the hours spent in education at the main registration. The subsidiary registration should **only** include the hours spent in education there.

There are three separate sections for this, one for two year olds, one for three year olds and one for four year olds as at the 31 August 2011 regardless of their National Curriculum Year group (NCY). The screens work in the same way and are accessed via **Tools | Statutory Return Tools | Update Hours at Setting for 4 year olds** and **Tools | Statutory Return Tools | Update Hours at Setting for 3 year olds** and **Tools | Statutory Return Tools | Update Hours at Setting for 2 year olds**

Update Hours for 4 year olds

Save Undo Help

Term: Spring Update Hours: Year Group: All Reg: All Status: All

Name	Date of Birth	Gender	AdNo.	Year Actual	Reg	Age	Hours at Setting	Funded Hours
Adams,Laura	03/03/2007	Female	001235	R	ELM	4	25	
Ammar,Tarak	05/02/2007	Male	001236	R	ELM	4	25	
Astwick,Gwenneth	21/02/2007	Female	001155	R	ELM	4	25	
Bond,Steve	10/10/2006	Male	001237	R	ELM	4	25	
Cameron,Zara	25/02/2007	Female	001156	R	PINE	4	25	
Carter,Hannah	28/04/2007	Female	001238	R	ELM	4	25	

To enter **Hours at Setting** and **Funded Hours** for an individual pupil, click in the appropriate column and enter the data. For a full-time pupil this will be 25 hours. If all your pupils are full-time, right click in the column heading and **select all**.

Update Hours for 4 year olds

Save Undo

Term: Spring Update Hours: Year Group: All Reg: All Status: All

Name	Date of Birth	Gender	AdNo.	Year Actual	Reg	Age	Hours at Setting	Funded Hours
Adams,Laura	03/03/2007	Female	001235	R	ELM	4	25	
Ammar,Tarak	05/02/2007	Male	001236	R	ELM	4	25	
Astwick,Gwenneth	21/02/2007	Female	001155	R	ELM	4	25	
Bond,Steve	10/10/2006	Male	001237	R	ELM	4	25	
Cameron,Zara	25/02/2007	Female	001156	R	PINE	4	25	
Carter,Hannah	28/04/2007	Female	001238	R	ELM	4	25	

Sort By
Select All

Right click, then Select All

Enter 25 and all the rows will fill automatically then do the same with the other column. Note that the Hours at Setting data will have been carried forward from last term but may need amending if you had pupils attending part-time last term who are now full-time. In the Spring Term the Funded Hours will be blank as this is the first time this data is being collected but the data you enter should be carried forward to the Summer Term.

If you have part-time pupils in Reception, record all hours the pupil attends at the setting. Funded Hours should only include education provision and should therefore exclude any hours of 'childcare' and breaks where the pupils are not receiving education. Extended schools services (e.g. breakfast clubs and after school clubs) should also be excluded as they are not considered to be education provision.

Hours for part-time pupils can be recorded to the nearest half hour (0.5). Periods of up to 15 minutes should be rounded down, periods of 15 minutes or more should be rounded up.

To enter information into a single field double click, type in the data, and enter or click elsewhere.

Note: You can select a group of neighbouring pupils by highlighting the first one, holding down the Shift key and highlighting the last pupil. Then enter the number of hours that applies to that group. Or you can select a group of individual pupils by selecting the first pupil, holding down the Ctrl key and selecting each of the others in turn, then enter the number of hours that applies to this particular group.

WARNING: There is a slight delay between entering the hours and their appearance on screen!

Update Hours for 4 year olds

Save Update

Click here to **Save** once you've entered the data.

Term: Spring Update Hours: Year Group: All Reg: All Status: All

Name	Date of Birth	Gender	AdNo.	Year Actual	Reg	Age	Hours at Setting	Funded Hours
Adams,Laura	03/03/2007	Female	001235	R	ELM	4	25	25
Amnar,Tarak	05/02/2007	Male	001236	R	ELM	4	25	25
Astwick,Gwenneth	21/02/2007	Female	001155	R	ELM	4	25	25
Bond,Steve	10/10/2006	Male	001237	R	ELM	4	25	25
Cameron,Zara	25/02/2007	Female	001156	R	PINE	4	25	25
Carter,Hannah	28/04/2007	Female	001238	R	ELM	4	25	25
Churchill,Martin	14/09/2006	Male	001239	R	ELM	4	25	25

Save before exiting.

Time in Unit

Time in Unit

Recalculate

Students

Name	Date of Birth	Gender	AdNo.	Year	Reg	Time in Unit
Atkinson,Thomas	25/03/1995	Male	000052	Y11	St Georg...	0
Barratt,Callum	01/09/1997	Male	000095	Yr 8 reg	Narita	0
Bennett,Kimberley	11/05/1995	Female	000070	Y11	Newport	0
Braund,Conor	05/05/1995	Male	000078			
Brayley,Chelsea	29/10/1994	Female	000133			
Brown,Devon	10/04/1996	Male	000081			

Click here to enter data

Update Time in Unit

The method of entering data is the same as Hours at Setting and Funded Hours, see above.

Please provide the number of contact hours each pupil spent with the PRU in the week of the census. This should include time in the PRU and, in the case of pupils receiving their education through home visits (or being educated in hospital), time spent in contact with staff members of the PRU.

Where the PRU has arranged for the pupil to receive their education via another establishment (eg an FE College or work-placement) then the time spent under the supervision of this establishment should be counted as part of the contact time. The PRU is also responsible for recording attendance at the other establishment.

In some cases pupils will remain in their registered school while being visited by PRU staff (through an outreach programme). This should **not** be included in the Unit Contact Time.

Pupils on a 'virtual' education programme who may not visit the PRU or receive a visit from a tutor in the census week should be recorded as having zero contact hours.

Pupil Status Module

Provider Status Recalculate

Students

Name	Date of Birth	Gender	AdNo	Year	Reg	FE College	Other Provider
Atkinson, Thomas	25/03/1995	Male	000052	Y11	St Georg...		
Barratt, Callum	01/09/1997	Male	000095	Yr 8 reg	Narita		
Bennett, Kimberley	11/05/1995	Female	000070	Y11	Newport		
Braund, Conor	05/05/1995	Male	000078	Y11	St Georg...		
Brayley, Chelsea	29/10/1994	Female	000133	Y11	St Georg...		
Brown, Devon	10/04/1996	Male	000081	Y10	Newport		

Update Provider Status

FE College and Other provider should only be ticked where the pupil is **only** registered at the PRU and receives the majority of their education at a FE College or Other Provider. Dually registered pupils must be recorded with enrolment statuses of 'M' (Dual main) at their main registration with 'S' (Dual Subsidiary) at the subsidiary registration.

Teachers

Teachers

Description	Type	FT(M)	FT(F)	PT(M)	PT(F)	PT Hrs(M)	PT Hrs(F)
Qualified Teacher	QT	5	5	2	6	41	75
Teachers not recognised as qualified	NQ	0	0	0	0	0	0
Teachers on schemes leading to Qualified Teacher Status	LQ	0	0	0	0	0	0
Teachers of Ethnic minorities	ET	0	0	0	0	0	0
Teachers of English as an Additional Language	LT	0	0	0	0	0	0
Total (excluding Teachers of Ethnic Minorities & Eng as an Additional Language)		5	5	2			

Recalculate

Click here to reflect any amendments you may make to your Personnel system

If the information has been generated automatically but is wrong, it is possible to amend your data in Personnel 7 and **Recalculate** to refresh *this* data without affecting any other section. In order for a teacher to be picked up in the School Census the Teacher indicator in Personnel 7 must be ticked and the Teacher Category set to the appropriate category e.g. Qualified Teacher.

Remember: Even though information may have come through automatically, you may still need to make manual adjustments, for example, for peripatetic teachers (e.g. Music Teachers) who may not be on your Personnel system if they are paid by parents.

Who to Include

Include **all** teachers who normally work at the PRU (during the school day, not including teachers working in extended school services), including all outreach and peripatetic teachers. The **source** of funding is immaterial for the purposes of the Census return and teachers funded from any source should be included: the fact that the teacher **normally** works at the PRU is the crucial factor.

Information is required for the following groups of teachers:

- a. Teachers normally employed at the school as at the Spring Census week (week beginning 16 January 2012) unless unusual arrangements occur in that week, in which case the normal situation should be recorded
- b. (as a subset of a.) Teachers normally employed who are teachers of minority ethnic pupils

Include:

- Peripatetic teachers who regularly teach at your school for at least one hour per week for at least a term (*including peripatetic Music teachers*)
- Staff on short term paid absence (*less than a term*)
- Relief staff covering long term absences (*a term or more*)
- Relief staff filling nominal vacancies

Exclude:

- Staff on long term paid absence (*a term or more*), for example on maternity or sick leave
- Staff on secondment.

In the above cases the absent teacher is, by virtue of the length of absence, no longer regarded as 'normally employed'

- Relief staff covering short term absence (*less than a term*), in these cases the absent teacher is still regarded as 'normally employed'
- Any vacancies not filled by relief staff
- Student teachers on School Centred Initial Teacher Training (ITT) courses

For all of the teacher categories, the information required includes the weekly directed hours of part-time staff. 'Directed hours' are the average hours per week for which a teacher is required to attend school, including assembly but excluding lunch breaks. A full-time teacher is considered to work 32.5 directed hours per week and the weekly directed hours of part-time teachers should be calculated on a pro rata basis. For each **part-time** teacher in each of the categories, the hours should be calculated according to the following table and then added up. The total should be rounded to the nearest whole number of hours (rounding 0.5 upwards). Please do **not** include the hours worked by Full-Time teachers.

0.1	=	3.25	0.6	=	19.5
0.2	=	6.5	0.7	=	22.75
0.3	=	9.75	0.8	=	26.0
0.4	=	13.0	0.9	=	29.25
0.5	=	16.25	1.0	=	32.5 (e.g. Job Share)

Where to Include Them

The categories for teaching staff are:

QT (Qualified Teacher): Teachers who have been awarded Qualified Teacher Status (QTS), following the successful completion of an approved course of initial teacher training (ITT), or via an alternative route (even if they have not passed induction). This field includes the Headteacher, Acting Headteacher and Deputy Headteacher

NQ (Teachers not recognised as qualified): Any person *without QTS* teaching as an unqualified teacher or instructor (even if they are on the qualified teacher pay spine) but excluding anyone on any scheme leading to Qualified Teacher Status. This may include Foreign Language Assistants and Instructors. (Foreign Language Assistants who hold a teaching qualification should be included in the **QT** category)

LQ (Teachers on schemes leading to Qualified Teacher Status): A person who is either waiting to start an ITT course for which they've been accepted, is currently undertaking an ITT course, or has completed an ITT course but not yet been awarded QTS. Students on teaching practice should **NOT** however, be included. Teachers in this category will be funded by either the school or the LA and should not be confused with student teachers on School Centred ITT courses.

Note: Teachers of Ethnic Minorities or English as an Additional Language should be included in one of the above main categories as well as in their specific categories shown below.

Teachers of Ethnic Minority Pupils or English as an Additional Language

Any teacher (already included in categories **QT, NQ & LQ**) who is employed at least partly to teach English as an additional language or to meet other needs of minority ethnic pupils should be included again here, with teacher type **ET** (Teachers of Ethnic Minority Pupils) or **LT** (Teachers of English as an Additional Language), as appropriate.

If a teacher:

is employed at the PRU **solely** to teach English as an additional language or to meet other needs of minority ethnic pupils, then their full or part-time status, and if part-time, their directed hours, will be the same here as under **QT, NQ or LQ**

but if:

they are not employed solely to teach English as an additional language or to meet other needs of minority ethnic pupils, then they should be counted as part-time here (even if they appear as full-time under **QT, NQ or LQ**, and their directed hours should be based on their time specifically related to the teaching of English as an additional language or meeting other needs of minority ethnic pupils.

NOTE: These teachers will be recorded twice but only counted once in **Total teachers in the above grid**

Support Staff

You may want to use the **Non-teaching Staff in PRUs** template available from the school census website www.devon.gov.uk/schoolcensus under Additional Guidance and Templates to assist you in completing the following section.

The screenshot shows a table titled "Support Staff" with columns for Description, Type, Post Count, and Hours. Below the table are two input fields: "Number of Full-Time Support Staff" (with value 5) and "Number of Part-Time Support Staff" (with value 6). A "Recalculate" button is visible on the right. Three callout boxes provide instructions: "Click in field to enter data manually" points to the Post Count column; "Ensure this information is correct for the number of people included above." points to the Total row; "Click here if you need to recalculate this section" points to the Recalculate button.

Description	Type	Post Count	Hours
High Level Teaching Assistant	HL	0	0
Special Needs Support Staff	SN	0	0
Minority Ethnic Pupils Support Staff - Bilingual Assistants	EB	0	0
Minority Ethnic Pupils Support Staff - Other	EQ	0	0
Teacher Assistants with Diploma in Childcare a		0	0
Teacher Assistants Without Diploma in Childcar		0	0
Matrons/Nurses/Medical Staff		0	0
Librarians		0	0
IT Technicians		0	0
Technicians		1	27
Total		11	284

Number of Full-Time Support Staff:

Number of Part-Time Support Staff:

If the information has been generated automatically but is wrong, it is possible to amend your data in Personnel 7 and **Recalculate** to refresh this data without affecting any other section but if only minor amendments are necessary e.g. Higher Level Teaching Assistants it is probably easier to manually amend this section.

Remember: *Even though information may have come through automatically, you may still need to make manual adjustments, for example, for paid staff not on your Personnel system.*

Who to Include

Information should relate to staff employed in school in the week beginning 16 January 2012 unless unusual arrangements occur in that week, in which case the normal situation should be recorded.

Include **all** appropriate education support staff who normally work at the school (during the school day, not including those working in extended school services), **regardless of how they are funded**

Include the following:

- staff on short term paid absence (*less than a term*)
- relief staff covering long term absence (*a term or more*)

Exclude the following:

- Staff on long term paid/unpaid absence (*a term or more*); - *for example on maternity or sick leave*. In these cases the absent staff is, by virtue of the length of absence, no longer regarded as 'normally employed'
- Relief staff covering short term absence (*less than a term*); *in these cases the absent staff member is still regarded as 'normally employed'*.
- Premises related staff such as caretakers
- Canteen staff, lunchtime supervisors (i.e. Meal Time Assistants) and lunchtime welfare assistants
- Anyone doing unpaid voluntary work
- Any support staff appointed to manage or support an Early years or Children's Centre provision where the children are not pupils of the school e.g. Children's Centre and Early Years Centre Manager.
- Clerks to Governors

For each **category** of support staff, you should enter in the relevant columns the number of staff and the total number of hours by 'post'. A member of staff may be recorded in more than one area under the Post Count.

The following examples highlight instances where the figures drawn from Personnel, may be incorrect.

Example 1 – *an unqualified teaching assistant who has two contracts for different Statemented pupils (each contract is for 0.2, making 0.4 in total i.e. 10.5 hours (which would be rounded to 11*)) and one general contract of 0.6. In the Special Needs (SN) category the system would show 2 contracts but this must be changed to 1 person in the Post Count column. The Teaching Assistants (UA) category will correctly show 1 person in the Post Count row and 16 hours. This person would be counted as one full-time person in the 'Number of Full-Time Support Staff' field*

**Calculation for hours based on 26.25 = full-time equivalence*

Example 2 – someone works 22 hrs per week as an admin officer and 15 hrs or more as a librarian (37 hours in total and therefore full-time). They should contribute 22 hours to the admin officer row (AO) and 12 hours to the librarian row (LI). They should be recorded in the Post Count column as one in each category. (This person would count as one in the Number of Full-time support staff.)

Example 3 – someone works 8 hours per week as a librarian, 5 hours as a secretary and 4 hours as a special needs teaching assistant (less than 37 hours in total and therefore employed on a part-time basis). Their hours should be recorded correctly for each category e.g. 8 hours in row LI, 5 hours in AO and 4 hours in SN and they would be counted in the Post Count column in each category (i.e. three times). (However, they would only be counted as one part-time member of staff in Number of Part-Time support staff.)

NOTE THAT: staff should be recorded and their weekly hours recorded on the basis of their normal working arrangements during **term time**, whether or not they work or get paid during school holidays.

For each staff type, once the weekly hours (excluding lunch breaks) of staff doing work of that type have been added up, the total should be rounded to the nearest whole number (rounding 0.5 upwards).

Where to Include Them:

Education Support Staff

Full-time equivalence = 32.5 (rounded to 33 hours) for Nursery Nurses (category QA) or (as a general rule) 26.25 hours for all other teaching assistants

HL Higher Level Teaching Assistant. HLTA is not a qualification. It is possible that someone could be using HLTA as a job title even though the person concerned has not been awarded HLTA status. Only those individuals who have been awarded HLTA status by the Training and Development Agency (TDA) formerly Teacher Training Agency, on behalf of the Secretary of State (SoS) should be counted. HLTA status is awarded to individuals who have demonstrated that they meet the national professional standards for HLTAs by successfully completing an HLTA programme at one of the providers who have been approved to deliver HLTA assessment and training programmes by the TDA. On successful completion of an HLTA programme they will be sent a letter awarding HLTA status by the TDA on the behalf of the SoS.

TA Teaching assistants other than for Special Needs (see below)

SN Special Needs Support staff

Minority Ethnic pupils support staff (*Full-time equivalence = 26.25 hours*)

EB Bilingual assistants

EO Others

Other Education Support Staff (*Full-time equivalence = 37hours*)

ME Matrons/nurses/medical staff

LI Librarians

IT IT Technicians

TE Technicians (*including laboratory assistants, design technology assistants, home economics and craft technicians*)

SS Other education support staff (*including welfare assistants in the classroom*, learning mentors (employed at the school), study supervisors, cover supervisors, any*

other education support staff regularly employed at the school (not covered in teaching assistants)

*Any staff designated 'welfare assistants' who only work lunchtimes are NOT to be included on this return.

Admin/clerical staff

Include only those who look after the administration of the school. Full-time equivalence = 37 hours

- AO Admin officers/secretaries
- AC Other admin/clerical staff
- BU Bursars (including School Business Managers)

IMPORTANT NOTE: Remember to enter the **Total number of full-time education support staff** and the **Total number of part-time support staff**. The total of these two figures may be less than or equal to the number of staff included in the Post Count column but on no account can it be **more than** the Post Count figure. (The total may be less than the Post Count total where one person has more than one role)

Pupil Attendance

Pupil Attendance

Your attendance codes are DCSF compliant
This will be rechecked at the Create & Validate stage

The screen above indicates that Attendance data for the last academic year has been **successfully** collected by the system. There is a Detail Report for Attendance and you are advised to check it carefully. If there are N codes please ensure they are reallocated to the correct absence code. If you make any changes to the data in the Attendance module you will need to recalculate this section and then **Create and Validate** the census.

The data collected from the Attendance module will be the aggregate number of possible attendance sessions, and the actual number of authorised and unauthorised absences **by reason for absence**.

If you see a screen with the following error message go to **Focus\Lesson Monitor\Deal with Missing Marks** (Note: you can continue with the remainder of the census before resolving this issue if you wish.)

Attendance

Some attendance marks are missing

Go to Focus\Attendance\Deal with Missing Marks
Please add attendance marks and then click 'Recalculate'

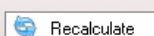
 Recalculate

If an invalid code has been used in error – go to **Reports\Lesson Monitor\ Selected Students Report\Students with chosen code report** Amend the **date range** to cover the appropriate period, change the **group type** to **whole school**, select the appropriate code on the **criteria** tab, for example, **W - do not use (Primary)**

Attendance data is required for day students of compulsory school age, who were on roll for at least one session in the academic year prior to this census. Please note that attendance data is only required up until 31 May 2011.

Teenage Mothers

Teenage Mothers	
Unit caters for teenage mothers	<input type="checkbox"/>
Number of places available for teenage mothers	<input type="text" value="0"/>
Unit provides childcare facilities	<input type="checkbox"/>

See Note

Please tick the appropriate boxes if the Unit caters for teenage mothers or provides childcare facilities. However, 'Number of places available for teenage mothers' should read 'Number of teenage mothers attending the PRU in the week of the census (ie week beginning 16 January 2012)'. If you have any teenage mothers on roll in the week of the census please enter the number you have otherwise please leave the default as zero.

Press **Save** to finish.

Create and Validate

Once you have entered/amended the data, please **Create and Validate** the return (see function keys in top left-hand corner). It is also advisable to print and **thoroughly** check the Summary and Detail Reports at this stage as it will allow you to assess the accuracy and completeness of the return. Once the validation has completed you may see some validation errors e.g.

Facility to search by error code: Select error code then click Search.

Type	Sequence	Message	Location	Solution
F	1000	Pupil reconciliation does not match number of Pupils		# Amend
F	1030	Teacher reconciliation does not match number of teach		# Amend
F	1070	Number of teachers in class is missing		# Go to
F	1340	Provision of Extended Services is missing		# Check Provision of Extended Services in Census
F	1420	Number of teachers with access to ICT is missing		# Please check Number of teachers with access to
F	1500	UPN missing	Name: Smiles, Sophie Date of Birth: 200	# Go to Focus Student Student Details and add or is
F	1630	Pupil aged 5 and over with ethnic group missing or in	Name: Graham, George Date of Birth: 2	# Go to Focus Student Student Details Ethnic/Cultur
F	1630	Pupil aged 5 and over with ethnic group missing or in	Name: Umbridge, Dolores Date of Birth:	# Go to Focus Student Student Details Ethnic/Cultur
F	1630	Pupil aged 5 and over with ethnic group missing or in	Name: Pocket, Preety Date of Birth: 200	# Go to Focus Student Student Details Ethnic/Cultur
F	1630	Pupil aged 5 and over with ethnic group missing or in	Name: Franklin, Paul Date of Birth: 2003	# Go to Focus Student Student Details Ethnic/Cultur

Double clicking on a specific error message will take you directly to the section that requires amendment. If you have a number of pupils who have the same error message it may be simpler to amend the data using the bulk update facility (**Routines | Pupil | Bulk Update**) rather than amend pupil details individually. Please remember that if you are using bulk update **after** the census date you will need to **back date the effective date ranges** for the changes to be reflected in the Census.

No failures (shown in red) are acceptable, except where they are as a result of a software error (PRUs will be notified (usually via the school census website www.devon.gov.uk/schoolcensus) where this is the case).

Queries (shown in black) are produced where the data is unusual or unexpected reflecting a potential inaccuracy or omission. They are acceptable where the data is true e.g. Sequence 2020Q, Message: *Please check: Pupil is shown in year group 5 however, pupil is aged 10* If this is true, ie pupil is taught in a year group other than expected by his/her age then the message is acceptable. If it is not true, the data must be amended.

Please note that error messages will not disappear, even though you may have made amendments to your data, until after you **Create and Validate** again. If the error message still appears and you are running this after the census date it is probable that there is 'history' attached to the field that was amended. This will mean backdating the history – see under Additional Guidance and Templates on the school census webpage. Data fields that have history attached are NCY, Ethnicity and First Language, some other fields e.g. part-time status, SEN, Gifted and Talented, Free School Meals and addresses have start and end dates which may need to be edited.

If you haven't already done so, please print the Summary and check it carefully along with the Detail Reports. Detail reports can be printed or you can open them up from Excel which allows you to sort the data any way you like.

Below is list of the reports – not all are applicable to PRUS eg Class Report. If you select 'Print All Reports' you have option to print out all or selected reports in one go.

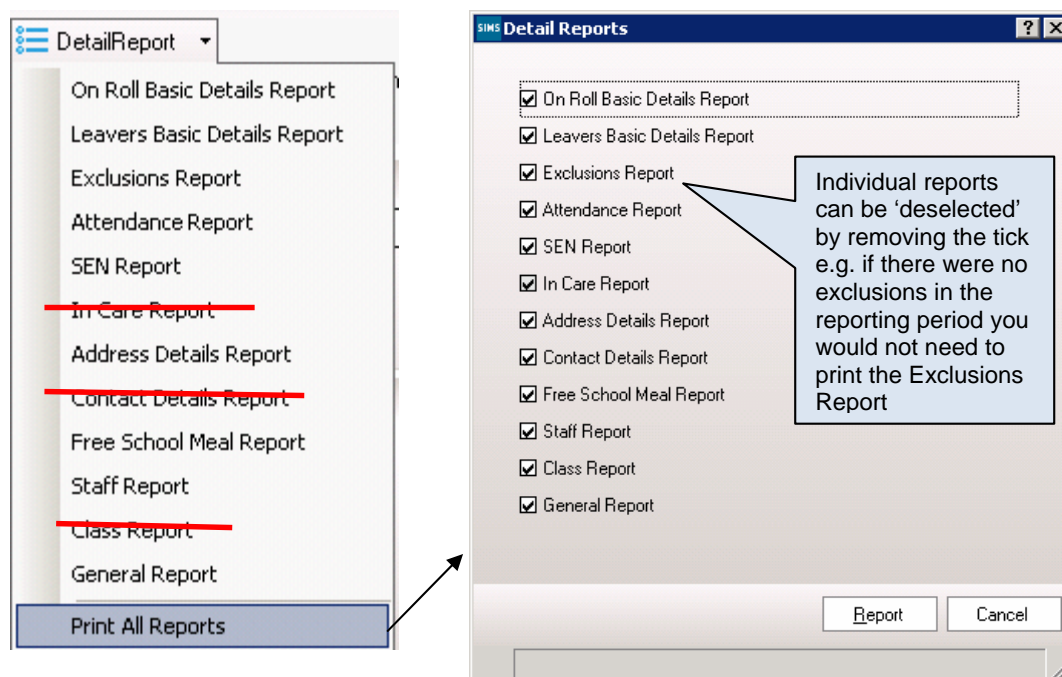

Remember: SIMS.net cannot know if there are pupils missing or that pupils have left (if they haven't been given a leaving date or a reason for leaving) etc. You **must** check the summary and detail reports thoroughly. The absence of any validation errors or queries does **not** guarantee a successful return!

Authorising and Copying Return

Once you are satisfied that your School Census is correct (all failures have been resolved, any queries are 'true' and the summary and detail reports are accurate), you need to authorise the return – if you are currently in the School Census click the **Authorise** button in the function keys in the top left-hand corner of the screen. You will see the following message:

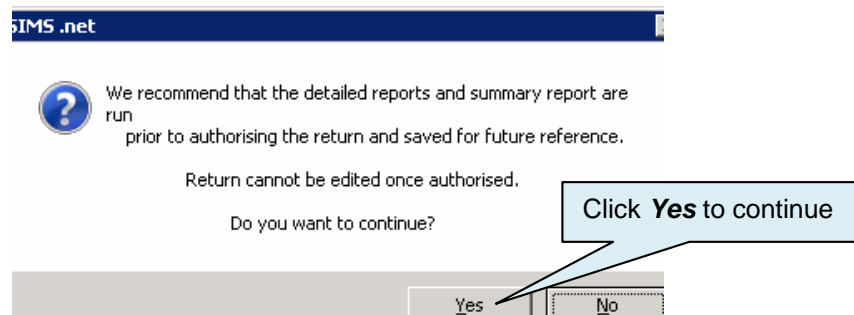

Note that once you have authorised the return it **cannot** be amended. However, you can copy the authorised return (it will appear 'greyed out' in the browser) by highlighting it and pressing the **Copy** button in the Census Return browser. Open up the newly created copy, give it a new description if you wish, amend and validate, authorise the copy and return the new file.

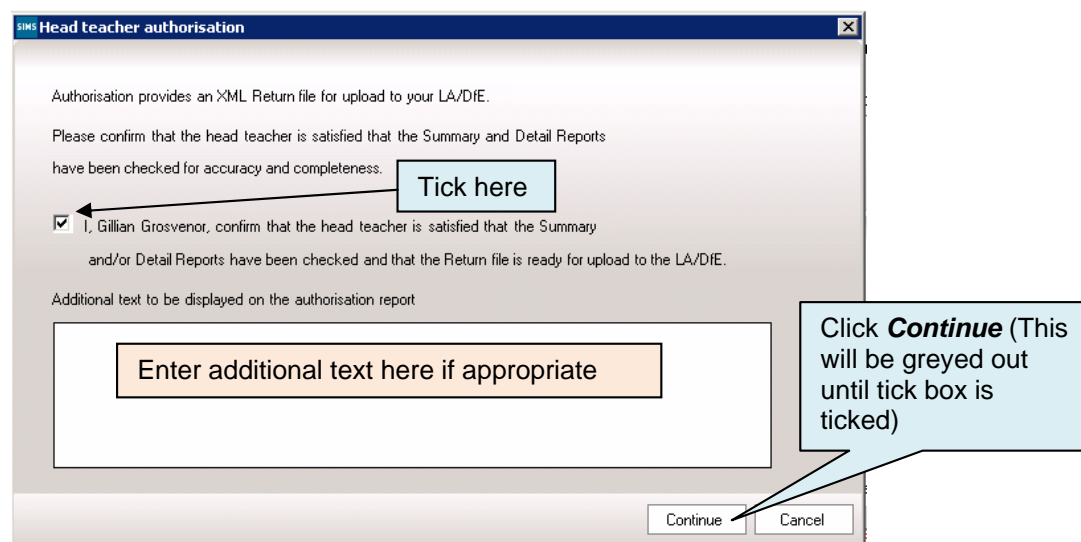

Once you click Continue you will have an opportunity to print the Authorisation and the Summary Report.

IMPORTANT NOTE: You must keep a paper copy of the School Census Summary report signed by the Teacher in Charge for audit purposes, it is also advisable to keep a set of the Detail Reports with it.

Returning your file

You must return your school census file to the LA via RMSecurenet Plus using the School Census community. The file name will be:

878nnnn_PRU_878LL12_aaa.xml

(where nnnn equals your four digit establishment number and aaa equals the file number (this will increment by 1 each time you create or copy a file)) Note: if the file extension reads .una instead of .xml you haven't authorised it. Please return to your School Census and authorise it before sending. You only need to send in the xml file – the Summary file will also be available to upload but it is not required.

When your census is received it will be loaded into COLLECT for you. This is usually done overnight. You may now add any necessary explanatory or confirmation notes into COLLECT without waiting for an email from Schools IDS. If you put it into the Return Level notes panel your note(s) will be retained even if you need to resubmit your census return. Guidance notes for adding notes to your file in COLLECT are available from the School Census website www.devon.gov.uk/schoolcensus The COLLECT web address is: <https://collectdata.education.gov.uk/COLLECTPortalLive/Login.aspx>

Schools on Terminal Server should select **RMSecurenet** on the launcher pad in SIMS.net to go to RMSecurenet.

What Happens Next

When your census is received it will be loaded into the DfE on-line data collection site, COLLECT, for you. This is usually done overnight. Please remember to add any necessary explanatory or confirmation notes into COLLECT the next working day. You do not need to wait for an email from SIDS (formerly IDS). If you put your notes into the Return Level notes panel your note(s) will be retained even if you need to resubmit your census return. Guidance notes for adding notes to your file in COLLECT are available from the School Census website www.devon.gov.uk/schoolcensus

In most cases 'Confirmed as correct' is sufficient but some queries may require additional explanation eg where a pupil has left and come back again. The DfE have requested that for **Error 1760** a more specific note is entered eg 'I confirm there are no pupils eligible for free school meals.'

We will also run your School Census against ONE (formerly EMS) the central pupil database and a variety of other checks made. If any errors are found you may be asked to supply a new file by SIDS.

Annexe 1 – School Information

Below are the fields required in **2 School Information** You can access the data via **Focus | School | School Details** or **Routines | Statutory Returns | School Census, 2 School Information**

<i>Field Name</i>	<i>Acceptable Values</i>
School Name	In full, including the words 'PRU', 'School' or 'College' if this is part of the school's full name
LA Number	878 Devon
Establishment Number	Your 4 digit DfE number (cost code)
School Phase	Should be PRU but may be Special or Secondary. The software will work regardless of the Phase but where it is other than PRU it will be amended centrally.
School Governance	Community
Intake Type	Comprehensive
Highest NCY	Enter the highest national curriculum year you cater for
Lowest NCY	Enter the lowest national curriculum year you cater for
School Address	Please record the school address, including postcode
Tel. No	Please enter the main PRU telephone number which is used for official purposes – please ensure the number is recorded with the area code.
E-mail Address	The e-mail address for official communications must be present and include the character @. The email address provided must be an account that is used on a regular basis and one that is accessible to the Headteacher e.g. head@ or office@. It would not normally be one that identifies a particular individual by name. This email address may be used for future DfE correspondence.

Annexe 2 – Pupil Information

Which Pupils should be included?

The registration of pupils is governed by section 434 of the Education Act 1996 <http://www.opsi.gov.uk/acts/acts1996/1996056.htm> and the Education (Pupil Registration) Regulations 2006 <http://www.opsi.gov.uk/si/si2006/20061751.htm> Section 434 specifies that all persons who are pupils at the school must be registered. Regulation 5 specifies the information that a school's admission register should contain, Regulation 8 specifies the circumstances under which a pupil can be removed from the register (for example, registration at another school, written notification of parental intention to educate at home, and long term absence (four weeks or more) where both the school and LA have failed after reasonable enquiry to locate the pupil.

A pupil would normally be dually registered in the following circumstances:

- a. Registered at a mainstream school (main school) but considered to need specialist support by attending a special school (subsidiary school) on a regular basis and, therefore, also registered at the special school
- b. Registered at a mainstream school (main school) but, because of e.g. behaviour problems, the pupil is also required to attend a PRU (subsidiary school) for part of each week and is, therefore, also registered at the PRU
- c. Registered at a special school or at a PRU (main school) but also attending another mainstream school (subsidiary school) on a regular basis as part of preparation for return to the mainstream school

Information should be provided for all pupils on the school's admission register (in accordance with Regulation 5 of the Education (Pupil Regulations 2006). This includes all pupils whose enrolment status is C (Current), M (Dual main), S (Dual subsidiary), F (FE College) or O (Other Provider) but excludes any pupil whose enrolment status is G (Guest). Note that:

- Children of service families registered at the school on Census day are no different to any other pupil registered at the school and will have an enrolment status of C (Current), M (Dual main), S (Dual subsidiary), F (FE College) or O (Other Provider). Provided that the pupil is registered at the school on Census day they should be included in the school return.
- Traveller children will be registered at one or more schools and will have an enrolment status of C (Current), M (Dual main), S (Dual subsidiary), F (FE College) or O (Other Provider) . Provided that the pupil is registered at the school on Census day they should be included in the school return.

If a pupil is no longer on the admissions register at your school on the Census day and you have already passed information (including UPN) on to their new school then you must not record the pupil on your School Census return. This does not affect the attendance and exclusion areas of the census. This applies whether the information has been passed on either verbally, in writing or via the Common Transfer File (CTF). Following this guidance should eliminate cases of double counting, any of which will be investigated.

For further guidance see 'DfE Detailed Guidance', available from the School Census website: www.devon.gov.uk/schoolcensus

For the purposes of the School Census return, the software will count a pupil as being on roll

when he/she meets all the following criteria:

- has an admission number
- has a date of arrival on or before the census date
- has a blank date of leaving or the date of leaving is in the future (i.e. after the census date)

For each pupil the information to be provided is given below. This information will be included in the School Census in each term unless otherwise stated or if a pupil has left:

The following information is held in Focus Pupil Pupil Details in the order in which it appears.	
<u>Basic Details</u>	
Legal Forename	In full, not shortened or familiar versions.
Middle Name(s):	In full, not shortened or familiar versions. If the pupil has no middle name(s) then this field must be left blank.
Legal Surname	Full legal surname , as the school believes it to be (schools are not necessarily expected to have verified this from a birth certificate or other legal document).
Preferred Surname	The surname most commonly used in the school. In full, not shortened or familiar versions. <i>Not required if pupil is no longer on roll</i>
Former Surname	This should only be completed if a former surname is already known to the school; otherwise this field should be left blank. Schools need not and should not take any special steps to establish the existence of former surnames of which they are not already aware. If the pupil has more than one former surname, record the most recently used. Previous names can be recorded under Basic Details by clicking on the 'History' button in this section.
Date of Birth	Must be present and correct and in dd/mm/yyyy format.
Gender:	M (male) or F (female)
Enrolment status	Must be one of the following Single registration Guest pupil (pupil not registered at this school but attending for some lessons or sessions – see below) Main dual registered (i.e. main school for a dually registered pupil) Subsidiary dual registered (i.e. subsidiary school for a dually registered pupil). <i>Pupils who are subsidiary dual registered do not receive funding from the DfE via the dedicated schools grant.</i> FE College Other Provider Guest pupils will be excluded from your School Census return since they are not properly on the register of the school. Giving them an enrolment status of guest will ensure this. If the pupil already has an enrolment status but it needs to be amended, go to Routines Pupil Change Enrolment Status (<i>This will only work on pupils admitted in this Academic Year.</i>)
Admission Date	Must be on or before the current census date for the pupil to be recorded on the School Census.
Former UPNs	This field can be blank. Where there is a former UPN e.g. a temporary UPN that has been replaced by a permanent one, it is expected to be in the correct format. However, it is not possible to amend a former UPN and as a result error numbers

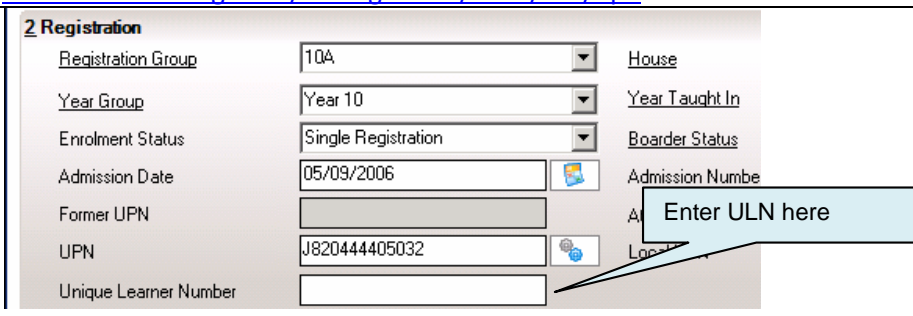
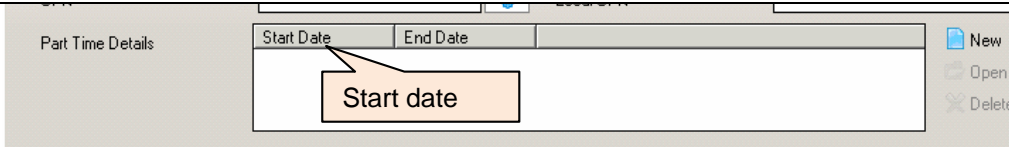
	1560Q and 1570Q can be ignored.
UPNs	<p>Make sure all pupils have a Unique Pupil Number. To issue a UPN click on the  icon beside this field. It should only be necessary to issue a new UPN when a pupil first enters the maintained school sector in England or Wales.</p> <p>If a pupil has transferred from another school (including LA designated Nursery Schools or Units) and you have no record of the UPN please contact the ScoMIS helpdesk on 01392 385300 who will be able to assist you.</p> <p>Temporary UPNs may only be issued as an interim measure until the permanent UPN is obtained. For further information see: www.teachernet.gov.uk/management/tools/ims/upn</p>
Unique Learner Number	 <p>This data item is only required for pupils studying for the new Diplomas award and grade.</p>
Part-time Indicator:	 <p>For a pupil to be recorded as part-time, there must be a start date in the Part-time Details panel under Registration. The date must be before the census date and is usually the same as the date of admission. For a pupil to be recorded as full-time this section must be blank or if there is a start date the end date must be before the census date.</p> <p>Note: <i>Part-time is only allowable for non-statutory age pupils. Part-time attendance is anything less than 10 sessions per week, and refers to part-time in education NOT just part-time in your school. E.G. a dually registered pupil who attends 3 full days at one school and 2 full days at another school should not be classified by either school as part-time. An exception may need to be made if the pupil is eligible for Early Years Funding – in which case please contact Jane Batten on 01392 383281 or email to census@devon.gov.uk</i></p> <p>For a pupil who is on a part-time timetable, for whatever reason, the school is authorising absence for the time the pupil is not timetabled to be present. For further guidance please see the school attendance website http://www.teachernet.gov.uk/wholeschool/behaviour/attendance/abdata/</p>
Year Taught In	<p>The year group in which the pupil is taught in for the majority of their time, regardless of their chronological age</p> <p>R reception 1-14 year groups 1-14</p>
Boarder	<p>B (boarder, nights per week not specified)</p> <p>N (not a boarder, i.e. day pupil)</p>

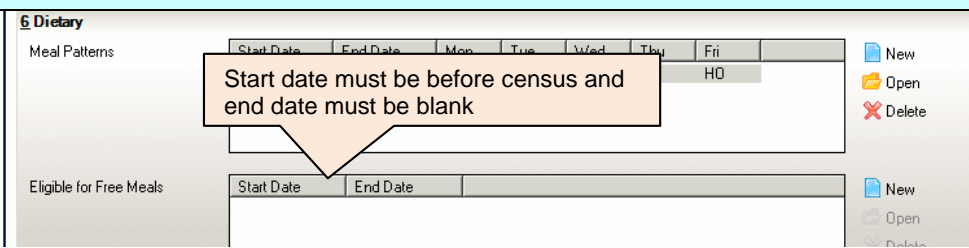
<u>Address</u>	
Home Information	<p>Schools are asked to provide home address for all pupils.</p> <p>The expectation is that you will be able to provide a valid home address for the great majority of your pupils (including boarding pupils). Boarding pupils from abroad should be recorded with their 'home' address as the address where they reside during term time, which may be the school's address. (If a second address is an overseas address, validation errors on the postcode can be ignored.) Where a child has multiple addresses (ie where the child lives with both parents at different stages of the week) both addresses should be supplied.</p> <p>Whilst every effort must be made to obtain these pupil details, in extreme cases this may not be possible. In such extreme cases fields can be left blank or a partial address can be supplied and the validation errors ignored.</p> <p>You may find the attached link of use in finding addresses and postcodes www.royalmail.com</p> <p>Note: For an address to be included in the school census the start date for the address must be before the census date and it must be the pupil's home address.</p>
<u>Dietary</u>	
Free School Meals Eligibility	 <p>To record a pupil as being eligible for Free Meals there must be a start date that is before the census date.</p> <p>Pupils should be recorded as eligible only if a claim for free school meals has been made by them or on their behalf by parents and either</p> <ol style="list-style-type: none"> (1) the authority has confirmed their eligibility and a free school meal is currently being provided by them, or (2) the school or the LA has seen the necessary documentation (e.g. a TC602 Tax Credit Award Notice) that supports their eligibility and the administration of the free meal is to follow as a matter of process. <p>Conversely, if pupils are in receipt of a free meal but there is confirmation that they are no longer eligible and entitlement will be revoked and the appropriate end date entered in the Eligible for Free Meals panel.</p> <p>Further information on eligibility is available from the following website: http://www.devon.gov.uk/free_school_meals.htm If in doubt, contact My Devon on ???</p> <p>If you wish to obtain a report showing you who is currently recorded as eligible for Free School Meals go to Reports Run Reports Student Meal List (Free Meals). This should match the Detail Report for Free School Meals from the census.</p>

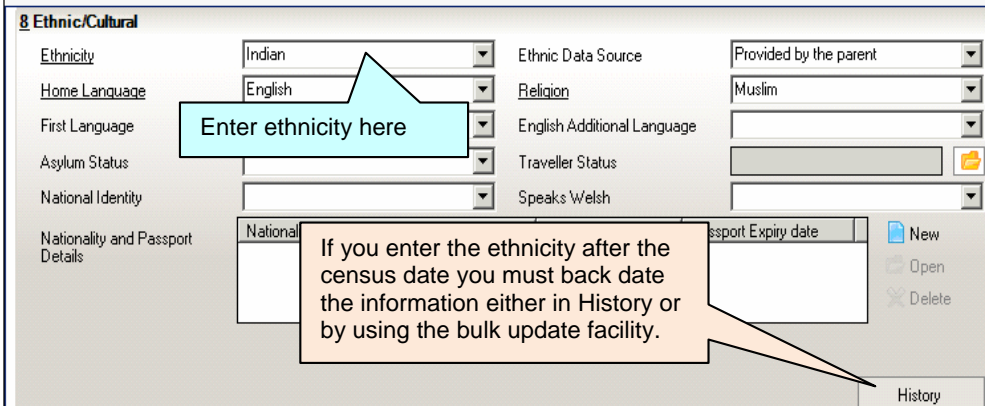
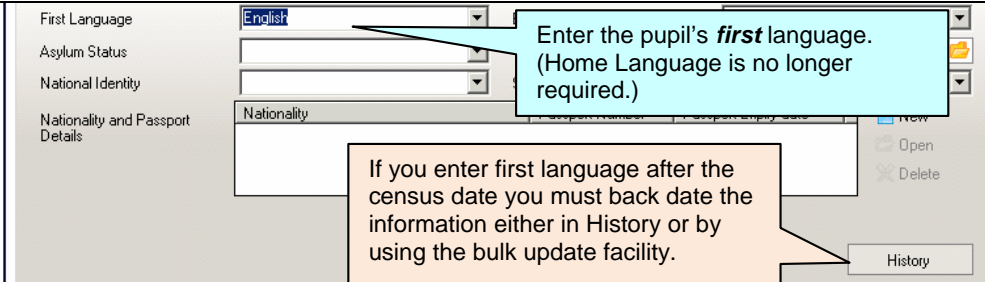
<u>Ethnic/Cultural</u>	
Ethnicity	 <p>All pupils aged 5 and over as at the previous 31 August should have an ethnic category assigned to them or if the information has not yet been collected 'Not Obtained' or if the parent has refused to give the information 'Refused'. A list of the ethnic codes that are being used in Devon LA Schools and establishments is available on the School Census website www.devon.gov.uk/schoolcensus Note: If you enter this information after the census date you will also need to go into History to back date this information, alternatively you can use 'Bulk update' and back date the 'effective' dates.</p>
First Language <i>formerly Mother Tongue</i>	 <p>A First Language other than English should be recorded where a child was exposed to the language during early development and continues to be exposed to this language in the home or in the community.</p> <p>If a child was exposed to more than one language (which may include English) during early development the language other than English should be recorded, irrespective of the child's proficiency in English.</p> <p>In the case of an older pupil who is no longer exposed to the first language in the home, and who now uses only another language, the school should consult with the pupil or parent to determine which language should be recorded.</p> <p>Where a pupil's first language is not English, schools may record specific languages from the extended language code set. ENB (Not known but believed to be English) and OTB (Not known but believed to be other than English) are appropriate where a pupil's first language is not known with absolute certainty because the parents have not responded to enquiries, but the school can judge with a high degree of confidence whether it is English or not. This is a compulsory field for all pupils aged 5 and over as at the previous 31 August.</p>

<u>Additional Information</u>	
Connexions Assent:	<p>Acceptable Codes:</p> <p>Yes Permission has been given by the parent or guardian</p> <p>No Parent or guardian has refused permission</p> <p>UNS Unsought- school has not yet sent out Privacy Notices (Data cannot be shared with Connexions)</p> <p>SNR Sought, No Reply – School has sent out Privacy Notices, but has received no reply from parent or guardian</p> <p>This field should be completed for all pupils who are aged 12 and above (as at 31 August 2011). If it is not completed the system will default to ‘unsought’. This information will be used to determine the information that can be passed on to Connexions on your behalf by the LA. This data item is not used by the DfE.</p> <p>There is a legal requirement under the Learning & Skills Act 2000 to pass information on request to the Connexions Service for pupils in or approaching the Connexions age range. The information which schools are required to provide consists of:</p> <ol style="list-style-type: none"> a) the names and address of pupils and their parents – which must be provided to the Connexions Service in any event; b) other information relevant to the provision of Connexions Services – in this case parents (or pupils themselves if aged 16 or over) have the right to instruct the school not to provide information to the Connexions Service. <p>The provision under (b) is for an opt-out. Until and unless the parent or pupil gives an instruction, the school remains under a statutory duty to provide information to the Connexions Service on request. Fair processing notices need to be issued to parents advising them of their (or their child’s) right to instruct the school not to provide information beyond name and address. If the following values are recorded: No or UNS (Unsought) then information beyond name and address cannot be shared with the Connexions Service.</p> <p>Further information on Connexions can be found at www.connexions.gov.uk</p>
Service Children in Education	<p style="text-align: center;">Service Children in Education <input type="text"/></p> <p>The Service Children Indicator will be used by the DfE in determining the Pupil Premium allocation for schools and as such it is essential that this data item is correctly recorded on the School Census. The rate for 2012 is £200.</p> <p>This indicates if a child has a parent or parents who are Service personnel, serving in regular HM Forces military units of all forces, or in the Armed Forces of another nation and stationed in England, and exercising parental care and responsibility. The information will be of use to help identify both the impact that being a Service child has on their education and the impact that catering for large numbers of Service children has on the school. Please note, however, that data on individual pupils is not being shared with the MoD.</p> <p>This is only relevant to children whose parents are designated as Personnel Category 1 or 2 which are shown on the MoD website, however all parents will be aware of the Personnel Category</p> <p>http://www.mod.uk/DefenceInternet/AboutDefence/CorporatePublications/PersonnelPublications/Welfare/PersonalStatusCategoryDefinitions.htm</p>

<u>Welfare</u>									
<p>In Care Details (For excluded pupils only)</p>	<div style="border: 1px solid #ccc; padding: 5px;"> <p>Welfare</p> <p>In Care Currently in Care</p> <table border="1" style="width: 100%; border-collapse: collapse;"> <thead> <tr> <th style="width: 25%;">Start Date</th> <th style="width: 25%;">End Date</th> <th style="width: 40%;">Care Authority</th> <th style="width: 10%;">PEP</th> </tr> </thead> <tbody> <tr> <td>30/11/2006</td> <td></td> <td>Devon</td> <td>0</td> </tr> </tbody> </table> <div style="text-align: right; margin-top: 5px;"> New Open Delete </div> </div> <p>This indicates whether a pupil is in the care of a Local Authority this does not include children looked after for short breaks (for respite care). This indicator is dependent on the information in the In Care Details panel' i.e. a Start Date in this panel will set the indicator to Currently In Care, a Start and End Date will set the Formerly In Care indicator. You must also enter the Care Authority where the child was originally placed in public care and which looks after the child for the purposes of the Children Act 1989. (This field becomes available when you click on new or open.)</p> <p>Schools will be informed (via an automatically generated email from the One (EMS) system of a change in status of a Child in Care) about all children who are in care and use the In Care indicator to record this. Those responsible for completing this return should liaise with the school's designated teacher for looked after children. The designated teacher should receive a Personal Education Plan (PEP) for each child who is in care (a PEP is a statutory requirement).</p> <p>Information on whether a pupil is In Care with Devon can be obtained via email to debbie.ford@devon.gov.uk</p> <p>Please Note: <i>There is the facility to indicate whether a pupil is on the Child Protection Register. This is not being collected on the 2011 School Census but may be in future.</i></p> <p>Under the Children's Act 1989, a child is looked after (or in care) by a LA if he or she is in their care or is provided with accommodation for more than 24 hours by the authority. They fall into four main groups:</p> <ol style="list-style-type: none"> i. children who are accommodated under a voluntary agreement with their parents (Section 20) ii. children who are the subject of a care order (Section 31) or interim care order (Section 38) iii. children who are subject of emergency orders for the protection of the child (Section 44 and 46) iv. children who are compulsorily accommodated. This includes children remanded to the LA or subject to a criminal justice supervision order with a residence requirement (Section 21). <p>In all cases Children and Young People Services (formerly Social Services) would be involved.</p>	Start Date	End Date	Care Authority	PEP	30/11/2006		Devon	0
Start Date	End Date	Care Authority	PEP						
30/11/2006		Devon	0						
<p>Date of Leaving</p>	<p>This is required for permanently excluded pupils (and hence no longer on roll). Please remember that for a pupil to be correctly recorded as a leaver they need a 'reason for leaving' to be recorded as well as the date of leaving.</p>								

Special Education Needs

The following fields are in **Focus | Pupil | SEN** or you can access the pupil in Pupil Details and then link to SEN

Basic SEN

SEN Provision (i.e. Status)

Ranking	Need Type	Description
1	Severe Learning Difficulty	

SEN Status codes are as follows:

- A** School action or early years action
- P** School action plus or early years action plus *
- S** Statement of SEN *
- N** No special educational need (*these pupils are not counted as having Special Educational Needs for the purposes of School Census*). If the Status field is blank, it will default to N.

Note: Please ensure the Start date is before the census date. If it isn't a previous status may be recorded on school census in error.

For further information on SEN Provision see

<http://www.teachernet.gov.uk/wholeschool/sen/teacherlearningassistant/>

SEN Needs Type

If the SEN status is P (School Action Plus or Early Years Action Plus) or S (Statemented) you must also record the pupil's main or primary need (Rank 1) and, if appropriate, their secondary need (Rank 2). You may record more for your own purposes but only the first two will appear in the School Census

If the pupil has a Statement of Special Educational Needs it is very important that the main primary need (Rank 1) matches the information on the Statement. **Note:** Any pupil who has been given an invalid Needs type will appear as a validation error (error 2170)

Valid codes are as follows:

- | | |
|------|--|
| SPLD | Specific Learning Difficulty |
| MLD | Moderate Learning Difficulty |
| SLD | Severe Learning Difficulty |
| PMLD | Profound & Multiple Learning Difficulty |
| BESD | Behaviour, Emotional & Social Difficulties |
| SLCN | Speech, Language & Communication Needs |
| HI | Hearing Impairment |
| VI | Visual Impairment |
| MSI | Multi-Sensory Impairment |
| PD | Physical Disability |
| ASD | Autistic Spectrum Disorder |
| OTH | Other Difficulty/Disability |

Guidance and descriptions of each type of SEN can be found at

www.teachernet.gov.uk/wholeschool/sen/datatypes/

Exclusions

The following fields are in **Focus | Pupil | Exclusions** or you can access the pupil in Pupil Details and then link to Exclusions (if you are amending details for a pupil who has been recorded as Permanently excluded, remember to change the view to Leavers)

Information on Exclusions is being collected for the previous academic year.

The exclusion start date should reflect the date the exclusion starts ie the date that the pupil was asked to leave the school by the Head Teacher. By not collecting the data until the academic year following the date the exclusion started, it is anticipated that all appeals procedures would have been completed by the time the data are collected and so only exclusions which have been upheld will be included in a return.

To add an exclusion click on **New** and you will see the following screen.

The screenshot shows a window titled 'Add Exclusion'. It contains the following fields and controls:

- Exclusion Details** (Section Header)
- Type: dropdown menu
- Reason: dropdown menu
- Start Date: text box with a calendar icon
- End Date: text box with a calendar icon
- Start Time: dropdown menu
- Length School Days: text box and a 'Calculate' button
- Part Time Exclusion: checkbox
- Comments: large text area
- Agency Involved: text box
- Academic Year: text box
- Term: text box

To edit or amend existing data, click in the appropriate row and click **open** to get to the screen above (which will have been completed).

If data has been entered in error, click on **Delete**

If you run the Exclusions Report that has been created for you it will collect the data for the required period. The data requirements for this section are as follows:

<p>Type</p>	<p>You must indicate the type of exclusion:</p> <p>FIXD Fixed Period *</p> <p>PERM Permanent</p> <p>LNCH Lunchtime *</p> <p><i>*You must also enter a Start Time (as well as a Start Date) for these types of exclusion but this is not collected in the School Census</i></p>
<p>Exclusion Reason</p>	<p>You must record the reason for the exclusion.</p> <p>PP Physical assault against a pupil</p> <p>PA Physical assault against an adult</p> <p>VP Verbal abuse/threatening behaviour against a pupil</p> <p>VA Verbal abuse/threatening behaviour against an adult</p> <p>BU Bullying</p>

	RA Racist abuse SM Sexual misconduct DA Drug and alcohol related DM Damage TH Theft DB Persistent disruptive behaviour OT Other
Exclusion Start Date	The exclusion start date should reflect the date the exclusion starts, i.e. the date that the pupil was asked to leave the school by the Head teacher. By not collecting the data until two terms after that in which the exclusion started, it is anticipated that all appeals procedures would have been completed by the time the data are collected and so only exclusions which have been upheld will be included in a return.
Length of School Days	There is a Calculate button that will do this for you, providing you also enter an End date . The calculation is based on the following: For each fixed period and lunchtime exclusion, the actual number of sessions for which the exclusion is in effect. For fixed period exclusions, each full school day counts as two sessions: a half school day counts as one session. For lunchtime exclusions, each lunchtime for which the exclusion applies counts as one session. Although information about reinstated exclusions are not being collected in the School Census, schools may wish to record the number of sessions for which the child was excluded before being reinstated and for this the actual, not the planned number of sessions should be recorded.

Attendance Data

This module will only be collected in the Autumn Term, providing information for a pupil's attendance in the Academic Year prior to the census up to the 1 June 2012.

This module will only be collected for day pupils of compulsory school age (pupils aged 5 before 1 September 2011 and aged 15 or younger on 31 August 2011).

The data required for each pupil will be the aggregate number of possible attendance sessions and the actual number of absences by reason for absence.

Sessions missed due to Authorised Absence

Authorised absence is absence which has been authorised by a teacher or other authorised representative of the school. Absence can be authorised retrospectively if the teacher or other authorised representative of the school subsequently 'accepts' a reason for the absence provided by a parent.

Sessions missed due to Unauthorised Absence

Unauthorised absence is absence without leave from a teacher or other authorised representative of the school. This includes all unexplained or unjustified absences.

Please ensure that there are no missing marks or 'N' codes in your data before running the school census.

Dual Registered pupils

From September 2011 the way schools should record attendance and absence for Dually Registered pupils changed.

Attendance code D (Dual Registered) is not counted in the School Census as an attendance. Each school will only need to record the attendance and absence for the sessions the pupil is required to attend at their school. Each school will use code D to record all of the sessions that the pupil is due to attend at the other school.

Pupils unable to attend school due to exceptional circumstances

Code Y (Unable to attend due to exceptional circumstances – not counted in possible attendances) will be collected as part of the School Census from 2012 following changes to attendance regulations and procedures.

Attendance code Y will be collected for statistical purposes. Schools will use code Y to record the sessions where a pupil is unable to attend because:

- The school site, or part of it, is closed due to an unavoidable cause;
- The transport provided by the school or LA is not available, and their home is not within walking distance; or
- A local or national emergency has resulted in widespread disruption to travel which has prevented the pupil from attending school.

As part of the changes to the attendance regulations and procedures the use of attendance code # is also being changed to include partial school closure. Previously it could only be applied to whole school closure.

It is acknowledged that details of the proposed changes to Attendance codes # and Y were given to software suppliers late in their development schedule and so it may not be possible for them to be implemented in time for the 2012 School Census collections. Until this change can be implemented in systems, school should continue to use code Y to record planned partial closure. The DfE acknowledges that data collected in the School Census in 2012 may include absences recorded under both the old and new definition of code Y and will acknowledge this in its published statistics using this data.

Persistent Absentee Thresholds

The DfE has reduced the threshold at which a pupil is defined as 'persistently absent' to 15%, down from 20% previously. Some schools tend to take action to intervene when pupils near the persistently absent threshold, but nearing 20% was too late. Lowering the threshold will help ensure that schools can take action sooner to deal with absence.

The table below shows the new thresholds against which absence statistics will be published in future. Initially, statistics will be published for both the 20% and 15% thresholds.

	Threshold sessions for Persistent Absence			
	20% Threshold		Newly introduced 15% Threshold	
	Threshold per Term	Cumulative	Threshold per Term	Cumulative
Autumn Term	28	28	22	22
Spring Term	24	52	16	38
Summer Term (1 st half)	12	64	8	46

Note: Attendance guidance information can be found on the DfE website at <http://www.education.gov.uk/schools/pupilsupport/behaviour/attendance/schoolattendancedata/a0010008/pupil-registration-regulations-and-guidance>

Annexe 3 - Flowchart

The process diagram below shows the steps that need to be taken to produce, check, authorise and

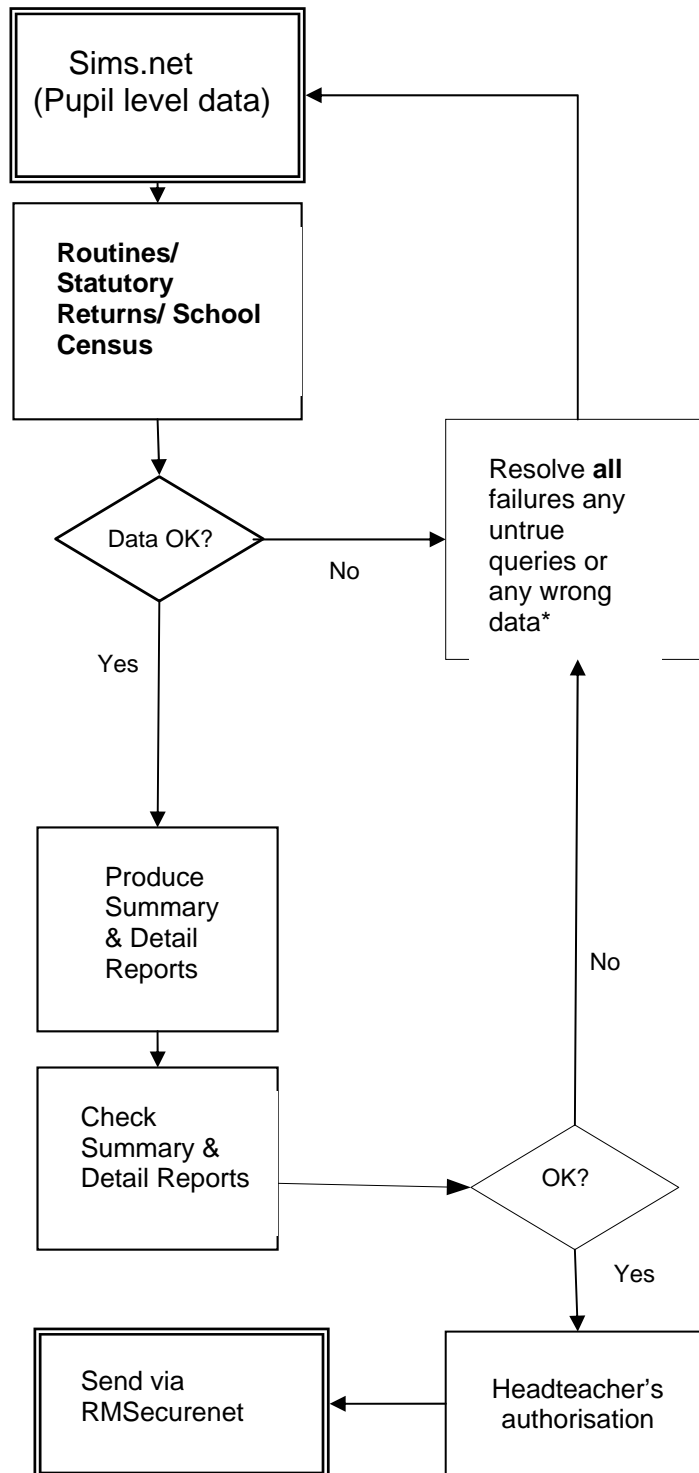

send each Census Return.

**Pupil errors and queries must be resolved at pupil level via Focus | Pupil Teaching and Support staff errors may be fixed via Personnel 7 or within the School Census, all other School level errors may be fixed within School Census.*